

CoroMill® 415

Small diameter, high feed face milling cutter

Application

- High feed face milling
- Plunge milling
- Ramping
- Roughing to semi-finishing
- Helical interpolation
- Profiling

ISO application area:



Benefits and features

- Versatile tool suitable for a wide range of applications
- Coolant channels for optimized chip evacuation
- Can be combined with the Coromant EH coupling and Silent Tools™ damped adaptors for vibration-free machining, high reliability and a significant productivity gain
- Unique iLock™ insert seat interface resulting in less scrap workpieces. The iLock™ insert seat also makes the small inserts easier to handle.
- Tailor made options available



www.sandvik.coromant.com/coromill415

Couplings

- Cylindrical shank
- Coromant EH
- Threaded coupling

Inserts

- Four cutting edges
- The unique iLock™ solution provides easy and accurate insert indexing, increased reliability and considerably improved tool life



I26



I29

CoroMill® 415 face milling cutter

Cylindrical shank - Internal coolant supply

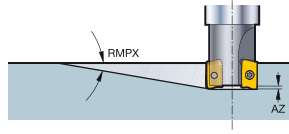

KAPR

15°

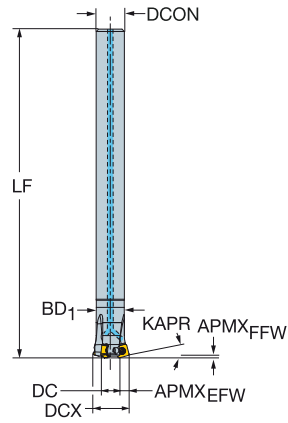

								Dimensions, mm									
DC	CZC _{MS}	APM _{EFW}	APM _{FFW}	RMPX	CNSC	Ordering code	DCON	DCX	BD ₁	LF	NM	KG	RPMX	CICT	MIID		
4.6	05	12	3.0	0.85	0.85°	1 2	415-013A12-05H	12.0	13.0	11.0	140.0	0.6	0.20	23600	2	415N-050206M	
7.6	05	12	3.0	0.85	0.97°	1 3	415-016A12-05H	12.0	16.0	12.0	140.0	0.6	0.20	21300	3	415N-050206M	
11.6	05	16	3.0	0.85	0.62°	1 3	415-020A16-05L	16.0	20.0	16.0	200.0	0.6	0.37	19000	3	415N-050206M	
	05	16	3.0	0.85	0.62°	1 4	415-020A16-05M	16.0	20.0	16.0	200.0	0.6	0.37	19000	4	415N-050206M	
	05	16	3.0	0.85	0.62°	1 5	415-020A16-05H	16.0	20.0	16.0	200.0	0.6	0.27	19000	5	415N-050206M	
13.5	07	20	4.5	1.20	0.61°	1 4	415-025A20-07H	20.0	25.0	19.0	200.0	1.2	0.50	15700	4	415N-070310M	
16.6	05	20	3.0	0.85	0.64°	1 5	415-025A20-05M	20.0	25.0	21.0	200.0	0.6	0.51	17000	5	415N-050206M	
20.5	07	25	4.5	1.20	0.63°	1 5	415-032A25-07H	25.0	32.0	26.0	250.0	1.2	0.86	13900	5	415N-070310M	

Spare parts	
	Insert screw
05	5513 020-28
07	5513 020-56

For complete list of spare parts, see www.sandvik.coromant.com



CoroMill® 415 face milling cutter

Coromant EH coupling - Internal coolant supply

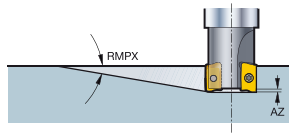

KAPR

15°

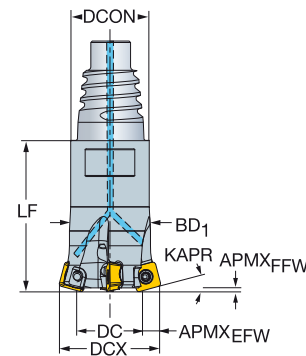

								Dimensions, mm											
DC		CZC _{MS}	APMX _{EFW}	APMX _{FFW}	RMPX	CNSC		Ordering code	DCON	DCX	BD ₁	LF			RPMX	CICT	MIID		
4.6	05	E12	3.0	0.85	0.85°	1	2	415-13EH12-05H	11.7	13.0	11.0	25.0	0.6	0.14	23600	2	415N-050206M		
7.6	05	E16	3.0	0.85	0.97°	1	3	415-16EH16-05H	15.5	16.0	12.0	30.0	0.6	0.18	21300	3	415N-050206M		
8.6	07	E16	4.5	1.20	0.56°	1	2	415-20EH16-07H	15.5	20.0	14.0	35.0	1.2	0.17	17500	2	415N-070310M		
	07	E20	4.5	1.20	0.56°	1	2	415-20EH20-07H	19.3	20.0	14.0	35.0	1.2	0.19	17500	2	415N-070310M		
11.6	05	E16	3.0	0.85	0.62°	1	4	415-20EH16-05M	15.5	20.0	16.0	30.0	0.6	0.05	19000	4	415N-050206M		
	05	E20	3.0	0.85	0.62°	1	4	415-20EH20-05M	19.3	20.0	16.0	32.0	0.6	0.07	19000	4	415N-050206M		
	05	E16	3.0	0.85	0.62°	1	5	415-20EH16-05H	15.5	20.0	16.0	30.0	0.6	0.16	19000	5	415N-050206M		
	05	E20	3.0	0.85	0.62°	1	5	415-20EH20-05H	19.3	20.0	16.0	32.0	0.6	0.19	19000	5	415N-050206M		
13.5	07	E20	4.5	1.20	0.61°	1	3	415-25EH20-07M	19.3	25.0	19.0	35.0	1.2	0.08	15700	3	415N-070310M		
	07	E25	4.5	1.20	0.61°	1	3	415-25EH25-07M	24.2	25.0	19.0	40.0	1.2	0.12	15700	3	415N-070310M		
	07	E20	4.5	1.20	0.61°	1	4	415-25EH20-07H	19.3	25.0	19.0	35.0	1.2	0.20	15700	4	415N-070310M		
	07	E25	4.5	1.20	0.61°	1	4	415-25EH25-07H	24.2	25.0	19.0	40.0	1.2	0.12	15700	4	415N-070310M		
16.6	05	E20	3.0	0.85	0.64°	1	5	415-25EH20-05M	19.3	25.0	21.0	32.0	0.6	0.08	17000	5	415N-050206M		
	05	E25	3.0	0.85	0.64°	1	5	415-25EH25-05M	24.2	25.0	21.0	35.0	0.6	0.12	17000	5	415N-050206M		
	05	E20	3.0	0.85	0.64°	1	6	415-25EH20-05H	19.3	25.0	21.0	32.0	0.6	0.20	17000	6	415N-050206M		
	05	E25	3.0	0.85	0.64°	1	6	415-25EH25-05H	24.2	25.0	21.0	35.0	0.6	0.24	17000	6	415N-050206M		
20.5	07	E25	4.5	1.20	0.63°	1	4	415-32EH25-07M	24.2	32.0	26.0	40.0	1.2	0.27	13900	4	415N-070310M		
	07	E25	4.5	1.20	0.63°	1	5	415-32EH25-07H	24.2	32.0	26.0	40.0	1.2	0.16	13900	5	415N-070310M		
23.6	05	E25	3.0	0.85	0.65°	1	7	415-32EH25-05H	24.2	32.0	28.0	35.0	0.6	0.16	15000	7	415N-050206M		

Spare parts	
	Insert screw
05	5513 020-28
07	5513 020-56

For complete list of spare parts, see www.sandvik.coromant.com



I29



L4



N22



N9



N15



N3

CoroMill® 415 face milling cutter

Threaded coupling - Internal coolant supply

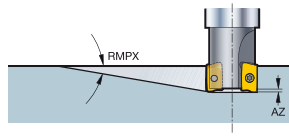

KAPR

15°

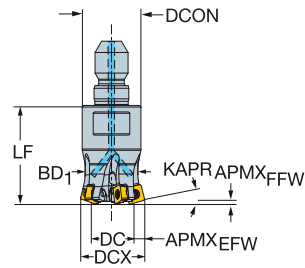

								Dimensions, mm								
DC	CZC _{MS}	APM _{KEFW}	APM _{FFW}	RMPX	CNSC	Ordering code	DCON	DCX	BD ₁	LF	NM	KG	RPMX	CICT	MIID	
4.6	05	M8	3.0	0.85	0.85°	1 2	415-13T08-05H	12.8	13.0	11.0	25.0	0.6	0.02	23600	2	415N-050206M
7.6	05	M8	3.0	0.85	0.97°	1 3	415-16T08-05H	12.8	16.0	12.0	25.0	0.6	0.03	21300	3	415N-050206M
11.6	05	M10	3.0	0.85	0.62°	1 5	415-20T10-05H	17.8	20.0	16.0	30.0	0.6	0.05	19000	5	415N-050206M
13.5	07	M12	4.5	1.20	0.61°	1 4	415-25T12-07H	20.8	25.0	19.0	38.0	1.2	0.09	15700	4	415N-070310M
16.6	05	M12	3.0	0.85	0.64°	1 6	415-25T12-05H	20.8	25.0	21.0	35.0	0.6	0.10	17000	6	415N-050206M
20.5	07	M16	4.5	1.20	0.63°	1 5	415-32T16-07H	28.8	32.0	26.0	40.0	1.2	0.19	13900	5	415N-070310M

Spare parts	
	Insert screw
05	5513 020-28
07	5513 020-56

For complete list of spare parts, see www.sandvik.coromant.com



CoroMill® 415 insert for milling

KRINS 15°

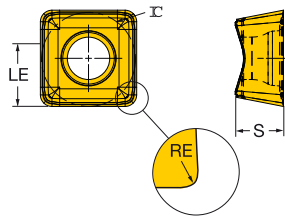
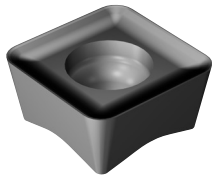

	RE	Ordering code	P				M				S			H		Dimensions, mm				
			T010	T030	T040	S40T	T030	T040	S30T	S40T	T030	H13A	S30T	S40T	T010	T030	IC	LE	S	
Medium	05	0.60	415N-05 02 06M-M30			☆	☆	☆	★	☆	★	☆	☆	☆	★	☆	☆	5.0	3.8	2.21
	07	1.00	415N-07 03 10M-M30			☆	☆	☆	★	☆	★	☆	☆	☆	★	☆	☆	7.0	5.0	3.07



126

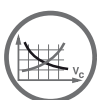

1146



1168



N22



N10