

CoroMill® 419

High-feed milling cutter

Application

- High feed face milling
- Profiling
- Ramping
- Helical interpolation
- Machining of components requiring long overhangs
- Suitable for low-powered machines and weak fixtures
- Roughing to semi-finishing

ISO application area:



Benefits and features

- High productivity in applications requiring light cutting action
- Long tool life, especially in difficult-to-machine materials
- Strong and robust inserts for reliable machining
- Low power consumption
- Through coolant on all cutters enables efficient wet machining as well as compressed air cooling
- Reduced axial forces with a 19 degree entering angle and a positive axial inclination angle

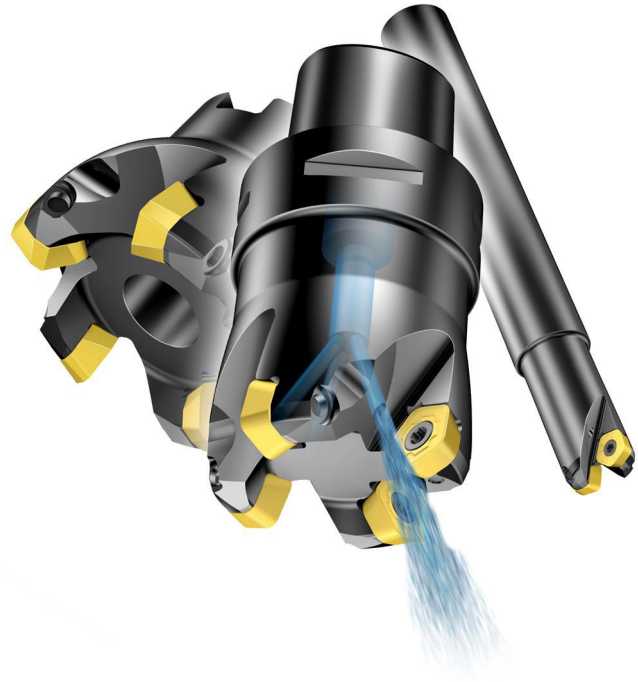

www.sandvik.coromant.com/coromill419

Couplings

- Coromant Capto®
- Arbor
- Cylindrical shank

Inserts

- Five cutting edges
- Inserts with parallel land for high feed face filling and radius inserts for pocketing
- Wide range of grades and geometries

L



Coarse pitch

M



Close pitch

H



Extra close pitch

Face milling



Face and Profile Milling



I17



I19



N6

CoroMill® 419 face milling cutter

Coromant Capto® - Internal coolant supply

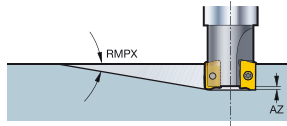

KAPR

19°

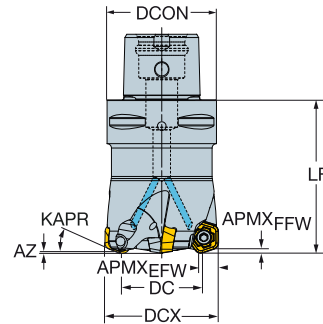

										Dimensions, mm							
DC	CZC _{MS}	APM _{EFW}	APM _{FFW}	RMPX	AZ	CNSC	Ordering code		DCON	DCX	LF	NM	KG	RPMX	CICT	MIID	
21.4	14	C3	8.0	2.00	9.00°	2.0	3	2	419-036C3-14L	32.0	36.0	50.0	5.0	0.36	22400	2	419R-1405
27.4	14	C4	8.0	2.00	8.00°	2.0	3	3	419-042C4-14M	40.0	42.0	70.0	5.0	0.70	19900	3	419R-1405
37.4	14	C5	8.0	2.00	8.00°	2.0	3	4	419-052C5-14M	50.0	52.0	70.0	5.0	1.08	17100	4	419R-1405
51.3	14	C6	8.0	2.00	6.00°	2.0	3	5	419-066C6-14M	63.0	66.0	70.0	5.0	1.73	14600	5	419R-1405
69.3	14	C8	8.0	2.00	5.00°	2.0	3	6	419-084C8-14H	80.0	84.0	70.0	5.0	3.02	12600	6	419R-1405

Arbor - Internal coolant supply

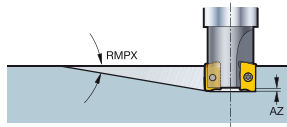

STDNO
KAPR

ISO 6462:2011
19°

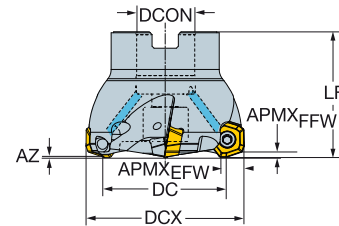

										Dimensions, mm								
DC	CZC _{MS}	APM _{EFW}	APM _{FFW}	RMPX	AZ	CNSC	Ordering code		DCON	ISO	DCX	LF	NM	KG	RPMX	CICT	MIID	
29.4	14	16	8.0	2.00	8.00°	2.0	1	3	419-044Q16-14M	16.0	A	44.0	45.0	5.0	0.37	19300	3	419R-1405
35.4	14	22	8.0	2.00	8.00°	2.0	1	3	419-050Q22-14L	22.0	A	50.0	45.0	5.0	0.56	17600	3	419R-1405
	14	22	8.0	2.00	8.00°	2.0	1	4	419-050Q22-14M	22.0	A	50.0	45.0	5.0	0.43	17600	4	419R-1405
37.4	14	22	8.0	2.00	8.00°	2.0	1	5	419-052Q22-14H	22.0	A	52.0	45.0	5.0	0.45	17100	5	419R-1405
39.4	14	22	8.0	2.00	8.00°	2.0	1	3	419-054Q22-14L	22.0	A	54.0	45.0	5.0	0.49	16800	3	419R-1405
	14	22	8.0	2.00	8.00°	2.0	1	4	419-054Q22-14M	22.0	A	54.0	45.0	5.0	0.47	16800	4	419R-1405
	14	22	8.0	2.00	8.00°	2.0	1	5	419-054Q22-14H	22.0	A	54.0	45.0	5.0	0.53	16800	5	419R-1405
48.3	14	22	8.0	2.00	7.00°	2.0	1	4	419-063Q22-14L	22.0	A	63.0	50.0	5.0	0.63	15100	4	419R-1405
	14	22	8.0	2.00	7.00°	2.0	1	5	419-063Q22-14M	22.0	A	63.0	50.0	5.0	0.62	15100	5	419R-1405
51.3	14	22	8.0	2.00	6.00°	2.0	1	4	419-066Q22-14L	22.0	A	66.0	50.0	5.0	0.67	14600	4	419R-1405
	14	22	8.0	2.00	6.00°	2.0	1	5	419-066Q22-14M	22.0	A	66.0	50.0	5.0	0.66	14600	5	419R-1405
	14	22	8.0	2.00	6.00°	2.0	1	6	419-066Q22-14H	22.0	A	66.0	50.0	5.0	0.65	14600	6	419R-1405
65.3	14	27	8.0	2.00	5.00°	2.0	1	5	419-080Q27-14M	27.0	A	80.0	50.0	5.0	1.07	13000	5	419R-1405
	14	27	8.0	2.00	5.00°	2.0	1	6	419-080Q27-14H	27.0	A	80.0	50.0	5.0	1.06	13000	6	419R-1405
69.3	14	27	8.0	2.00	5.00°	2.0	1	6	419-084Q27-14M	27.0	A	84.0	50.0	5.0	1.17	12600	6	419R-1405
	14	27	8.0	2.00	5.00°	2.0	1	7	419-084Q27-14H	27.0	A	84.0	50.0	5.0	1.15	12600	7	419R-1405
85.3	14	32	8.0	2.00	0.00°	2.0	1	6	419-100Q32-14M	32.0	B	100.0	50.0	5.0	1.68	11400	6	419R-1405
	14	32	8.0	2.00	0.00°	2.0	1	7	419-100Q32-14H	32.0	B	100.0	50.0	5.0	1.69	11400	7	419R-1405

Spare parts
Insert screw 5513 020-78

For complete list of spare parts, see www.sandvik.coromant.com



CoroMill® 419 face milling cutter

Cylindrical shank - Internal coolant supply

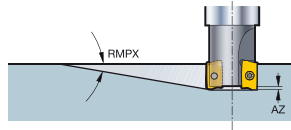

KAPR

19°

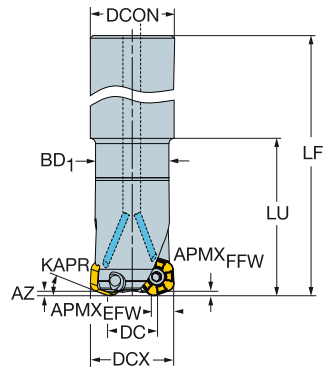

										Dimensions, mm									
DC	CZC _{MS}	APM _{EFW}	APM _{FFW}	RMPX	AZ	CNSC	Ordering code			DCON	DCX	BD ₁	LF	LU	NM	KG	RPMX	CICT	MIID
17.4	14	32	8.0	2.00	10.00°	2.0	1	2	419-032A32L-14L	32.0	32.0	28.0	250.0	60.0	5.0	1.54	24700	2	419R-1405
25.4	14	32	8.0	2.00	8.00°	2.0	1	3	419-040A32L-14M	32.0	40.0	28.0	250.0		5.0	1.62	20600	3	419R-1405

Spare parts
Insert screw
5513 020-78

For complete list of spare parts, see www.sandvik.coromant.com



